

# Artificial Vision for Blinds using Technological Language

L. Cordova, F. Escudra, A. Hurtado, M. Iman, L. Lino, *Students from the third year in engineering*  
Advisor Mario Chauca member AOTS, IEEE and Ricardo Palma University-Perú

**Abstract**—This project is a prototype that works thanks to four sensors stage, an audio generator stage, a switching stage, and another stage of single amplifiers for each earphone which generates an audio signal established by a protocol of sounds.

This singular protocol has variables like amplitude, frequency and continuity of the audio signal. Each sensor is made off a transmitter whit its receptor of infrared signal. Once we have developed the sensor, we proceed to calibrate it until reaching the desired range. The audio generator stage is an astable oscillator that changes its frequency depending on the signal that is received by the sensors. The switching stage has been designed by a transistor that works as a switch, working in the cut and saturation state. The amplifiers are designed for little signals generating two levels of amplitude adequate to the human ear.

The first zone includes frontal sensors to detect obstacles and regulates the signal frequency for the sound in both headphones depending of the distance of the obstacles.

The second zone includes surface sensors; these generate a change in the signal amplitude in the sound for headphones in two values, a high one, and a low one, it depending on whether or not there is a vacuum in the surface.

The third and fourth zone includes lateral obstacle's sensor calibrated at an specific distance that modifies the audio signal corresponding to each headphone in an independent way between two levels, a continuous and a discontinuous one.

**Keywords**— Transistor, photodiode, Circuit Integrate 555, Relay, Protocol, Sensor, Prototype.

## I. NOMENCLATURE

IRLED	: Infrared Light Emitting Diode
PH	: Potential of Hydrogen
RTD	: Resistance Temperature Detector
PIC	: Peripheral Interface Controller
VCO	: Voltage Controlled Oscillator

## II. INTRODUCTION

**T**he Blindness is one of the biggest problems that our society faces, Despite the big effort that is being made for

---

This work was supported in part by the Engineer Faculty of Ricardo Palma University.

L. Cordova, F. Escudra, A. Hurtado, M. Iman, L. Lino, students from the third year in electronic engineer is with the Ricardo Palma University, District Surco, Lima-33 PERÚ (e-mail: 200612586@mail.urp.edu.pe, 200616923@mail.urp.edu.pe, 200612640@mail.urp.edu.pe, 200616068@mail.urp.edu.pe, 200616076@mail.urp.edu.pe).

Advisor Mario Chauca is with the Ricardo Palma University, District Surco, Lima-33 PERÚ and Association for Overseas Technical Scholarship (e-mail: mchauca@mail.urp.edu.pe).

trying to fight against this illness and all the medical improvements, these facts are not able to stop the inevitable reality, cause there are many people that can be saved from blindness, but they live depending of many expensive treatments and the unlucky people that can't afford this kind of treatment get irremediable blind.

There are also people that are born blind, that are why in many places the solution to this problem is not being searched but how to live with it in better conditions. Some solutions are well known, like a blind staff a guide dog and many others.

This has brought a better adaption to our society for these impaired people, but they still don't feel as a normal person.

[3] The general objective of this project is to create a prototype that could allow blind people to reinsert into the society, it may not be perfect but it would be another step in the fight against blindness. Another goal of this project is to be into the reach of everybody, a fact that would decrease the amount of people who are excluded due to their blindness and so, the could have more chances to integrate easily into the society. [4]

The prototype has been designed with a four sensors base that makes a scanning to the area that surrounds the impaired person. It has sensors on the front zone and on the sides as well as a sensor that allows us to recognize the surface state of the path where the person walks along warning us whenever an obstacle is found by sounds that are emitted by the prototype. These sounds can be heard through an earphone that is linked with the prototype.

When the sensors are activated or deactivated, the audio generator stage will make a variation in the sound, changing the amplitude, frequency and continuity of the sound as well as different sounds on each ear, a characteristic that will greatly help the blind person for having a better knowledge of the place where he is walking, giving him more confidence on himself.

“The sensor is a device that is able to transform physical or chemical magnitudes, called instrumentation variables, in electrical magnitudes. The instrumentation variables depend of the sensor type and those variables can be temperature, bright intensity , distance , acceleration, inclination , movement, pressure, strength , torque, humidity, pH, etc”.[5]

An obtained electrical magnitude can be an electric resistance, an electric capacity (as in a humidity sensor), An electric voltage (as in a thermocouple), an electric current (as in phototransistor), etc.

And once the current is obtained, it is decision of the manufacturer to do whatever he thinks is appropriated with the received signal, in our case, the sensors that we're making have to react with the distance, which is going to be calibrated in a range that allows the impaired to take quick decisions about what he is going to do when an obstacle is on his way.

This prototype is intended to have an improvement like a digital signal processing stage (it can be designed using a PIC microcontroller or a microprocessor).

This stage will receive the information from the frontal, obstacle sensors, the surface and lateral sensors and another one of inclination that will allow us to generate, with more exactitude, a sound's pattern that helps the blind person in the taking of decision while walking.

"The VCO is a device that generates an oscillating output (Square or triangular Wave), which frequency can be adjusted in a range controlled by a direct current voltage. The frequency of its output signal is controlled by the input voltage". [6]

The digital processing stage in an advanced version, will include a VCO stage that will receive the voltage level of the sensors, adapted to a range that is needed to generate a frequency belonging to a frontal obstacle distance, this means that while the frontal obstacle distance changes, the frequency will be changing at the same time.

It is also possible to identify the distance, the obstacle's shape as well as its color, for this purpose we would have to use a microcontroller that can compare the information of the sensors of distance and color using a color database for each preset distance.

The only problem that hasn't been solved yet would be the way to send this information to the blind person because it can't be sent through an audio protocol.

### III. TECHNICAL WORK PREPARATION

The sensor to be used in this prototype is a photoelectric one; it's an electronic device that replies to the change of the light intensity. These sensors require of a Light emitter component and a receptor component that receives the Light generated by the emitter.

All the different ways of scanning are based in this working principle. They're designed especially for detection, classification and object's arrangement; the shapes and colors detection and the difference in level detection, even under extreme atmospheric conditions.

Particularly, the infrared sensor is an Electronic device that is able to measure the electromagnetic radiation of all the bodies or shapes on its sight range.

All these bodies reflect a quantity of radiation, it is invisible for our eyes but not for these electronic devices cause they are just below the visible light in the spectrum range.

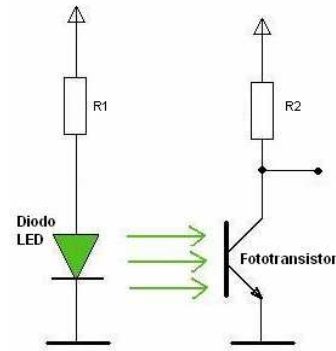

Figure 1. - Sensor circuit, made by the emitter and receiver circuit.

A special variant of the photodiodes is the infrared photodiode, the IRLED diode; it's an infrared ray's emitter which is an electromagnetic radiation set in the electromagnetic spectrum, from the visible light to the microwave.

The differences between these diodes and the LED diodes are the plastic color which is blue or grey. The diameter of this plastic cylinder is generally of 5mm

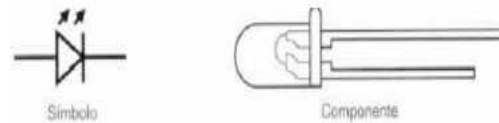

Figure 2. - Symbol and a real image of a photodiode

The infrared rays are emitted in more or less intensity by any object at a temperature above the absolute zero.

The phototransistor is a Photo detector that Works as a classic transistor, but normally it doesn't have a base connection.



Figure 3. - Phototransistor

In these transistors, the base is replaced by a photosensitive crystal, that when it gets light, produces a current and the transistor starts operating. In the phototransistor, the current circulates in a way in the transistors depends of the intensity of the light, with more light; there will be a greater current. The phototransistor reacts with the infrared light that is invisible.

In our prototype, the sensor that presents in each face, both the LEDs, as the phototransistor. Due to this configuration, the system has to measure the radiation coming from the reflex of the light emitted by the LED, that are designed especially for the detection, classification and positioning of objects; the detection of shapes, colors and surface differences, including under extremes environmental conditions. The difference with a normal LED is that the light emitted is not visible for the human eye; it can only be perceived by others electronics devices.

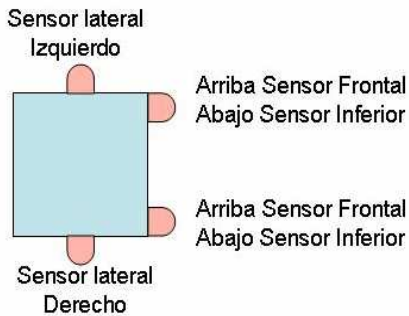

Figure 4. - Prototype with sensors located

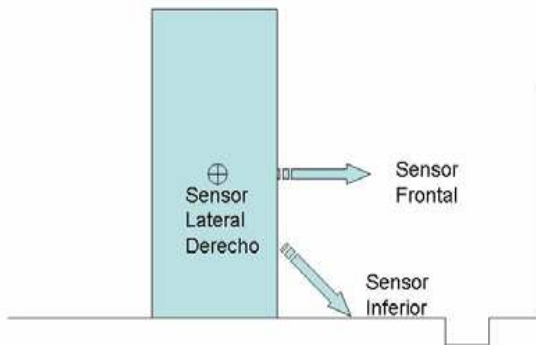

Figure 5. - Operation of the prototype to detect any obstacles

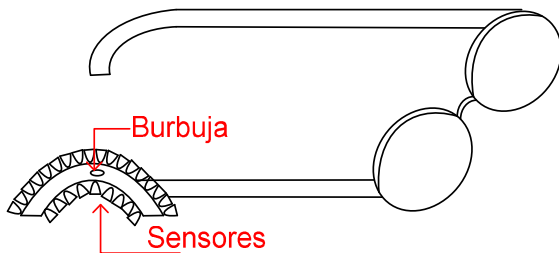

Figure 6. - Inclination sensor's schematic

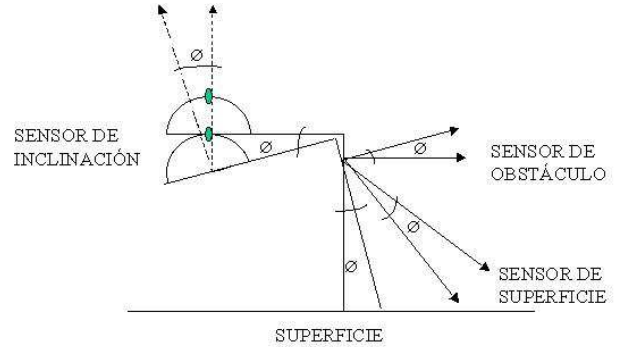

Figure 7. - Operation of the Inclination sensor

The relay is a magnetically operated switch. This is activated or deactivated, depending of the connection, when the electromagnet, which is part of the relay, is energized. This connection is achieved with the attraction or repulsion of a small arm, called armor, by the electromagnet.

These tiny arms connect or disconnect two or more terminals of this device.

If the electromagnet is active, it pulls the arm (armor) and connects the points C D. If the electromagnet is deactivated, it connects the points D E. This way you can put something while the electromagnet is active and other when it is inactive.

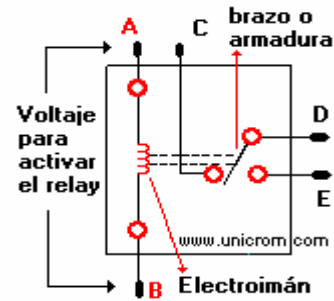

Figure 8. - Operation of the relay

The operation of the relay in our circuit depends of the values that will be provided by the sensor, it means that when the sensor detects that there is no obstacle, the relay will be deactivated, that will be our first state, which means that according to our sound protocol that it will be in state "0", when the obstacle arrives and the sensor detects it, it will send a logic "1" activating the relay changing the switch to the other state, and now the new state in our protocol will be "1."

For the demonstration of the application of the prototype, we will simulate a block of Wood that is a blind person, in which we will place the sensors in the next positions: two sensors on the front, two looking down, and the other two at both sides of the block.

Then we start driving the mobile manually through the labyrinth and using as a guide through sound protocol previously learned, then, we will realize that the sensors are detecting the obstacles and holes that are in the in the path, thus leaving the labyrinth.

At the end of the path and out of the labyrinth it will be demonstrated the efficiency of the prototype and the impact that this will have for blind person.

#### IV. RESULTS AND DISCUSSION

The infrared sensor detects an obstacle which is located within 2cm distance that could be located in front of him or in a straight line, which means that at the time we found the obstacle, the LED turns on, so we're going to get an specific sound, depending of that we'll know what we're going to do, which means going right, left, stop, or going straight.

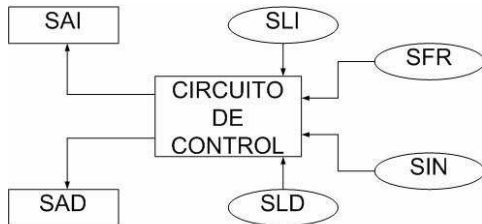

Figure 9. - Prototype with sensor's location

This block represents the blind person, in which we'll place each one of the sensors, for what we'll observe the operation in the following table:

PROTOCOLO				
SENSOR	NOMENCLATURA	ESTADO	AUDIO	SIGNIFICADO
Frontal	SF	1	Alta Frecuencia	Obstáculo frontal
Frontal	SF	0	Baja frecuencia	Sin obstáculo frontal
Inferior	SI	1	Alta Amplitud	Desnivel en el piso
Inferior	SI	0	Baja Amplitud	Sin desnivel en el piso
Lateral	SLI	0	Continuidad	Con vacío lateral
Lateral	SLD	1	Discontinuidad	Sin vacío lateral

Table 1. - Operation Protocol of the circuit

The Table 1 show us the sound circuit, in which it will indicate me what to do depending of the intensity of the sound that the blind person will listen, if this one is low, acute, intermediate or others. This will indicate me the decision that the blind person which in this case, it will be the prototype.

Componentes	Voltaje (V)		Corriente (mA)	
Relay	Sin obstáculo	0	Sin obstáculo	0.2
	Con obstáculo	5.6	Con obstáculo	21.4
Emisor	1.2		24.9	
Receptor	Sin obstáculo	12.9	Sin obstáculo	0
	Con obstáculo	11.8	Con obstáculo	0.12
Estado normalmente abierto	2.215		15.02	
Estado normalmente cerrado	2.171		15.10	
Distancia: 2.5 cm.				

Table 2. - Voltage and current measure

The data obtained on the table 2 are the measures that we have realized in the following way: the voltage in the relay that has been measured between the points of the coil, in both states where there are no obstacle and when the circuit detects the presence of the object, we do the same in the case of the receptor, the voltage measured on the emitter maintains, and the voltage in the normally open state is obtained by detecting the obstacle and last one, the voltage measured in the normally closed state is measured when there is no obstacle.

The measured currents in all the devices have been taken putting it at open circuit, the current in the relay and in the receptor have been taken in their both states. In the cases of the normally open state and closed we can observe that the current that passes through them is 15 mA, which guarantees us that the LEDs are functioning correctly.

Having explained the end of our project and the utility it has, we can realize more We can do more work in it and develop it, so that we can improve it in all its aspects thus ensuring the comfort and easy use of this prototype, is been thought that in the future we could place rows of sensors in glasses that just as the sticks that blinds persons use, it will allow the individual to capture the atmosphere and environment in which they conduct their daily lives and will be even better because it would allow the user to have both hands free, something that was impossible with the use of a cane

These infrared glasses will work with the same principle that its prototype, already explained just that for more effectiveness,

It must be improved some of its features such as the power of the sensory part, to have a greater distance for data capturing, referring to potential obstacles.



Figure 10. - Final version of the glasses

## V. CONCLUSIONS

- The use of this project will end by allowing the blind person to mobilize and conduct their activities in a safe and reliable way.
- In the demonstration of the prototype, the mobility of the body can be made in a very varied way, in a manually way, or you can also use a mobile machine, since the main purpose is to demonstrate the ability to detect, determine what type of obstacle stands, and dodging with the help of the sound protocol
- In an applicative way the circuit could be implemented in a pair of glasses connected to a headset, for greater efficiency and for a more comfortable handling.

## VI. ACKNOWLEDGMENT

The authors gratefully acknowledge the contributions of the Ricardo Palma University by the Rector PhD. Ivan Rodriguez, Engineering Faculty of Ricardo Palma University by the Dean PhD. Leonardo Alcayhuaman, Laboratory of Circuits and Devices by the boss eng. Rafael Taipe, engineers' staff and The our Adviser and Professor PhD. Graduated Mario Chauca.

## VII. REFERENCES

### Books:

- [1] A. Sedra y K. Smith, "Circuitos Microelectronicos", 5ta ed., México: McGraw-Hill, 2006, pp. 210-211 y 419-420.
- [2] Boylestad, Robert L.: "Electrónica: Teoría de Circuitos", 6ta ed., Editorial Prentice Hall ,1997 p. 130.

### Links:

- [3] Mira [web-based]\*. Canadá: Fundación Mira Inc. 2001 [acceso 22 de julio de 2008]. Jóvenes ciegos [about 20 screens]. Available at:  
<http://www.mira.ca/contente/s1-1-2e.html>
- [4] La jornada [web-based]\*. Mexico: DEMOS, Desarrollo de Medios, S.A. de C.V. [updated on April 15, 2005]. Científico mexicano desarrolla lentes para que los ciegos vean [about 3 screens]. Available at:  
<http://www.jornada.unam.mx/2005/04/15/a02n1cie.php>
- [5] Wikipedia [web-based]\*. EEUU: Wikimedia foundation. Inc. [updated on July 3, 2008; accessed July 22, 2008]. Sensor [about 3 screens]. Available at:  
<http://es.wikipedia.org/wiki/sensor>.
- [6] Wikipedia [web-based]\*. EEUU:Wikipedia foundation Inc. [updated on September 28, 2008; accessed October 10, 2008]. Voltage-controlled oscillator [about 3 screens]. Available at:

[http://en.wikipedia.org/wiki/Voltage-controlled\\_oscillator](http://en.wikipedia.org/wiki/Voltage-controlled_oscillator)

- [7] AllDatasheet [web-based]\*. EEUU: Datasheet [Access Oct. 10, 2008]. 74LS124 - voltage-controlled oscillators - Texas Instruments [about 10 screens]. Available at:  
<http://pdf1.alldatasheet.com/datasheet-pdf/view/28062/TI/74LS124.html>